

HEADLAMP ADJUSTING ASSEMBLIES AND COMPONENTS

	PAGE
HEADLAMP ADJUSTING SCREW ASSEMBLIES	
AMERICAN MOTORS & TRUCKS244
CHRYSLER243
FORD240
GENERAL MOTORS238
HEADLAMP ADJUSTING SCREWS245
HEADLAMP ADJUSTING SPRINGS	
CHRYSLER252
FORD251
GENERAL MOTORS249
HEADLAMP NUTS PIVOTS & SPACERS246
MISCELLANEOUS HEADLAMP PARTS	
BEARING PADS, BUSHINGS & RETAINERS252

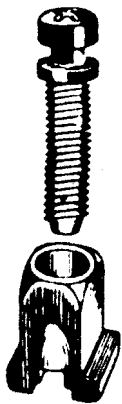

HEADLAMP ADJUSTER ASSEMBLIES GENERAL MOTORS



67-3095
HEADLAMP ADJUSTING
NUT & SCREW ASSEMBLY
1-1/2" Screw
G.M. Cars '62/
UNIT PACKAGE 25 KITS

67-3110
HEADLAMP ADJUSTING
NUT & SCREW ASSEMBLY
1" Screw
G.M. Cars '62/
UNIT PACKAGE 25 KITS

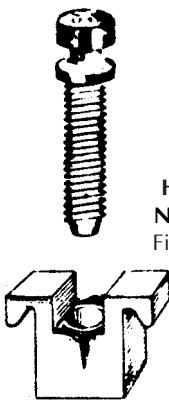

68-3249
Replaces: 1231451
HEADLAMP ADJUSTING
NUT & SCREW ASSEMBLY
Firebird '68, G.M. '69 - '72
UNIT PACKAGE 25

PATENTED

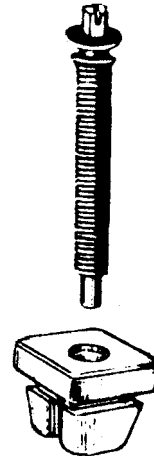

67-3124
HEADLAMP ADJUSTING
NUT & SCREW
G.M. Cars '68
UNIT PACKAGE 25 KITS

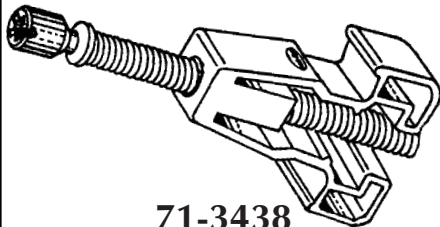

71-3438
Replaces: 1600375
HEADLAMP ADJUSTING
NUT & SCREW
1/4" - 28 x 1 1/2" Screw
Cadillac, Toronado '71/
UNIT PACKAGE 25

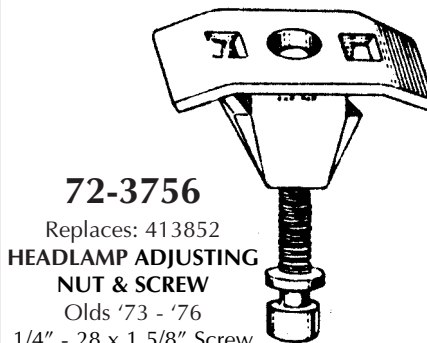

72-3756
Replaces: 413852
HEADLAMP ADJUSTING
NUT & SCREW
Olds '73 - '76
1/4" - 28 x 1 5/8" Screw
"B", "C", & "E" Bodies
UNIT PACKAGE 25



74-4076
Replaces: 354076
HEADLAMP ADJUSTING
NUT & SCREW
1/4" - 28 x 2" Screw
Buick '75/
UNIT PACKAGE 25

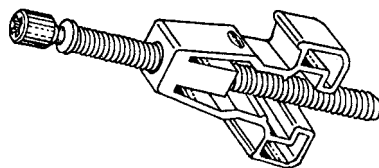

76-4313
Replaces: 1606642, 1618890
HEADLAMP ADJUSTING
NUT & SCREW ASSEMBLY
Pink
1/4" - 28 x 2" Screw
Cadillac '75/
UNIT PACKAGE 25

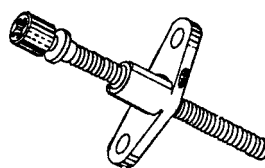

75-4195
Replaces: 417360
HEADLAMP ADJUSTING
NUT & SCREW
Nylon
Olds '75 - '76, Buick '76
UNIT PACKAGE 25

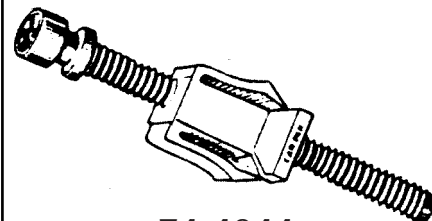

74-4044
Replaces: 343541, 3921446
HEADLAMP ADJUSTING
NUT & SCREW
1/4" - 28 x 2" Screw
Chevrolet '75/
UNIT PACKAGE 25

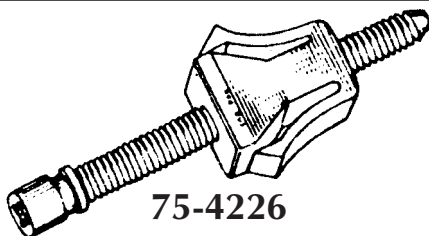

75-4226
Replaces: 364574
HEADLAMP ADJUSTING
NUT & SCREW
White
1/4" - 28 x 2" Screw
Buick '76/
UNIT PACKAGE 25



76-4252
Replaces: 365266
HEADLAMP
NUT & SCREW ASSEMBLY
Green
1/4" - 28 x 2" Screw
Chevrolet Caprice '75/
Full Size Cars '76/
UNIT PACKAGE 25

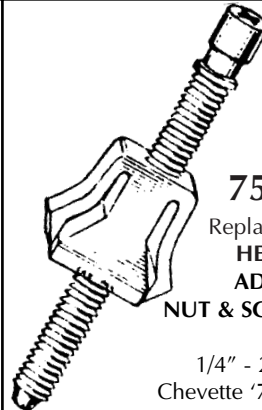

75-4224
Replaces: 343543
HEADLAMP
ADJUSTING
NUT & SCREW ASSEMBLY
White
1/4" - 28 x 2" Screw
Chevette '76/, Mini Van '85/
UNIT PACKAGE 25



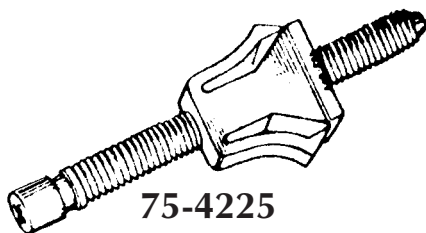

75-4225
Replaces: 343544
**HEADLAMP ADJUSTING
NUT & SCREW ASSEMBLY**
1/4" - 28 x 2" Screw
Chevrolet '76/
"ST" Trucks
UNIT PACKAGE 25

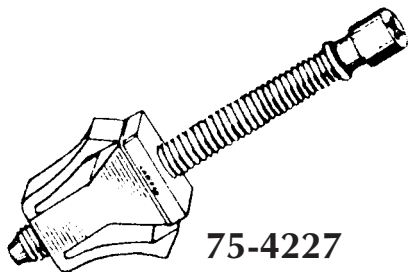

75-4227
Replaces: 364576
**HEADLAMP ADJUSTING
NUT & SCREW ASSEMBLY**
1/4" - 28 x 2" Screw
Buick '76/
UNIT PACKAGE 25

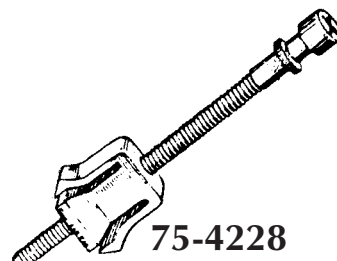

75-4228
Replaces: 362378
**HEADLAMP ADJUSTING
NUT & SCREW ASSEMBLY**
1/4" - 28 x 2 1/4" Screw
Chevrolet '76/
UNIT PACKAGE 25

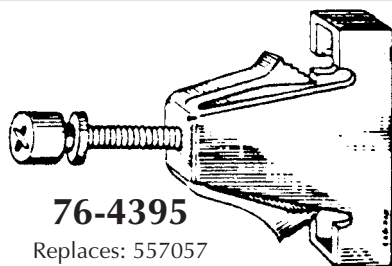

76-4395
Replaces: 557057
**HEADLAMP ADJUSTING
NUT & SCREW ASSEMBLY**
Blue
12 - 28 x 1 3/4" Screw
Pontiac '77/, "A" Body '82/
"P", "C" Body '85/
UNIT PACKAGE 25

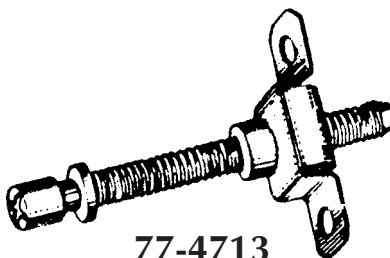

77-4713
Replaces: 1252690
**HEADLAMP ADJUSTING
NUT & SCREW ASSEMBLY**
1/4" - 28 x 1 5/8" Screw
Buick
UNIT PACKAGE 25

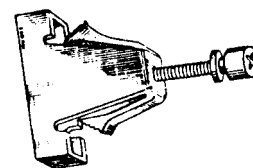

76-4380
Replaces: 556539
**HEADLAMP ADJUSTING
NUT & SCREW ASSEMBLY**
Black
12 - 28 x 1 3/8" Screw
Olds, Buick '77/
UNIT PACKAGE 25

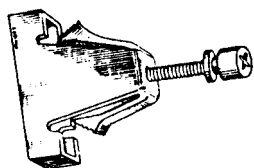

76-4381
Replaces: 556196
**HEADLAMP ADJUSTING
NUT & SCREW ASSEMBLY**
White
12 - 28 x 1 3/8" Screw
Olds '77/
UNIT PACKAGE 25

85-5915

Replaces: 22512857
HEADLAMP ADJUSTER ASSEMBLY
White
Slotted Torx
Screw M5 x 35MM
G.M. "B", "C", "G",
"E" & "X" Bodies '82/
UNIT PACKAGE 10

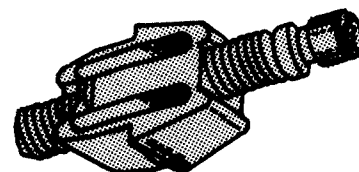

87-6198
Replaces: 16507452
**HEADLAMP ADJUSTING
NUT & SCREW ASSEMBLY**
M5 x 34MM Slotted Torx Screw
Horizontal or Vertical Adjustment
G.M. "J" Bodies '87/
UNIT PACKAGE 10

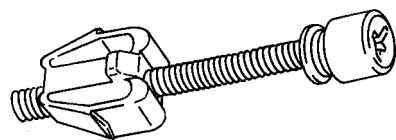

99-7986
Replaces: 15649136
HEADLAMP-ADJUSTING NUT & SCREW
#12-24 X 2" Screw
T15 Torx Recess
G.M. Truck '87/'91
UNIT PACKAGE 5

HEADLAMP PARTS



FORD



65-1054
UNIVERSAL HEADLAMP
ADJUSTING NUT & SCREW
 1/4" - 28 x 1 1/2" Screw
 Ford Products '61 - '72
 UNIT PACKAGE 100

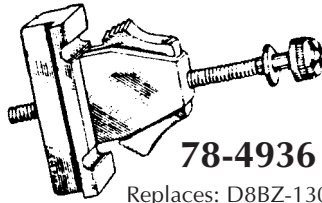

78-4936
 Replaces: D8BZ-13032A
UNIVERSAL HEADLAMP
ADJUSTING NUT & SCREW
 Ford Fairmont '78/
 Full Size Ford & Mercury
 Mustang & Pinto '79/
 Mercury Zephyr '79/
 Bobcat '79/
 UNIT PACKAGE 25

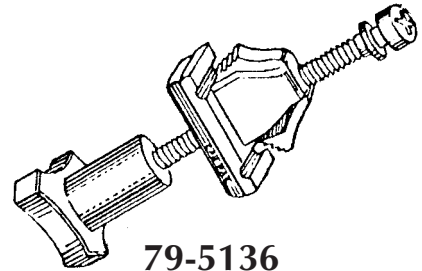

79-5136
 Replaces: E0VY-13032A
HEADLAMP ADJUSTING
NUT & SCREW ASSEMBLY
 Cougar & Lincoln '80/
 UNIT PACKAGE 10

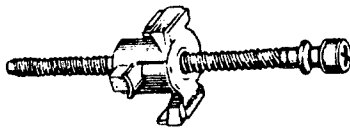

78-4970
 Replaces: D9ZZ-13032A
HEADLAMP ADJUSTING
NUT & SCREW ASSEMBLY
 Ford '79/
 UNIT PACKAGE 25

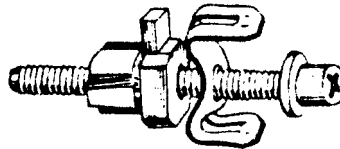

79-4993
 Not Supplied By O.E.
HEADLAMP ADJUSTING
NUT & SCREW ASSEMBLY
 Imported
 Ford Fiesta '78/
 UNIT PACKAGE 10

ESCORT & LYNX

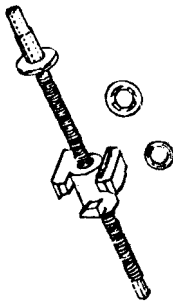

86-6032
 Replaces: E6FZ-13032B
HEADLAMP ADJUSTING
NUT & SCREW ASSEMBLY
 w/'O' Ring & Retainer
 For Aerodynamic Headlamp Designs
 Horizontal Adjustment
 Escort, Lynx '85 - '87
 UNIT PACKAGE 5

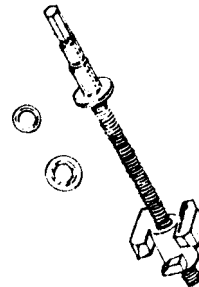

86-6033
 Replaces: E6FZ-13032C
HEADLAMP ADJUSTING
NUT & SCREW ASSEMBLY
 w/'O' Ring & Retainer
 For Aerodynamic Headlamp Designs
 Vertical Adjustment
 Escort, Lynx '85 - '87
 UNIT PACKAGE 5

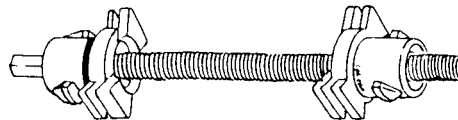

VERTICAL
 Brown nut-99-8201. Gray Pivot-99-8203
 found on page 249.

90-6782
 Replaces: E8FZ-13032C
HORIZONTAL
 Screw: M6 x 71.3MM O/L
 Clear Chromate Finish
 Brown Nut, Gray Pivot
 Escort, Lynx '88/
 UNIT PACKAGE 5

PROBE



91-6886

Replaces: E92Z-13032A
**SCREW-HEADLAMP ADJUSTER-
 VERTICAL**
 M5-0.8 x 55MM Phillips Recess
 Use 89-6705 Nut
 Ford Probe '88/
UNIT PACKAGE 15

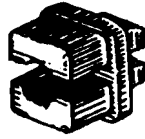

89-6705

Replaces: E92Z-13A147A
GROMMET NUT-HEADLAMP ADJUSTER
 Plastic
 Ford Probe '89/
UNIT PACKAGE 25

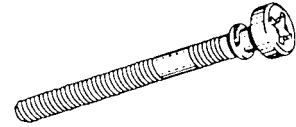

91-6887

Replaces: E92Z-13032B
**SCREW-HEADLAMP ADJUSTER
 HORIZONTAL**
 M5-0.8 x 40MM Phillips Recess
 Use 89-6705 Nut
 Ford Probe '88/
UNIT PACKAGE 15

TAURUS & SABLE

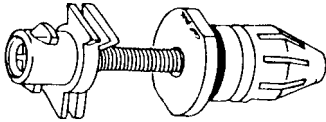

90-6778

Replaces: E9DZ-13032C
HEADLAMP ADJUSTER PIVOT
 Screw: M6 x 63.4MM O/L
 Black Chromate Finish
 Black Nut, Gray Pivot
 Taurus, Sable '89/
UNIT PACKAGE 5

TEMPO & TOPAZ

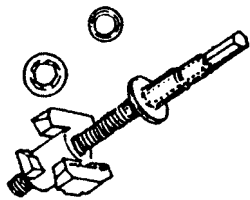

87-6229

Replaces: E63Z-13032B
**HEADLAMP ADJUSTING
 NUT & SCREW ASSEMBLY**
 w/'O' Ring & Retainer
 For Aerodynamic Headlamp Designs
 Horizontal Adjustment
 Tempo, Topaz '86 - '87
UNIT PACKAGE 10

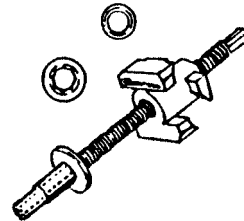

87-6228

Replaces: E63Z-13032A
**HEADLAMP ADJUSTING
 NUT & SCREW ASSEMBLY**
 w/'O' Ring & Retainer
 For Aerodynamic Headlamp Designs
 Vertical Adjustment
 Tempo, Topaz '86 - '87
UNIT PACKAGE 10

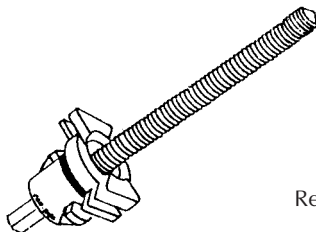

90-6779

Replaces: E83Z-13032A
 Horizontal
 Black Pivot
 12 - 28 x 76.0MM O/L
 Black Chromate Finish
 Tempo, Topaz '88-'91
UNIT PACKAGE 5

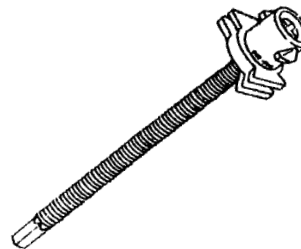

90-6780

Replaces: E83Z-13032B
 Vertical
 Black Pivot
 12 - 28 x 63.5MM O/L
 Clear Chromate Finish
 Tempo, Topaz '88-'91
UNIT PACKAGE 5

HEADLAMP PARTS



T-BIRD, COUGAR, GRAND MARQUIS, CROWN VICTORIA & CONTINENTAL

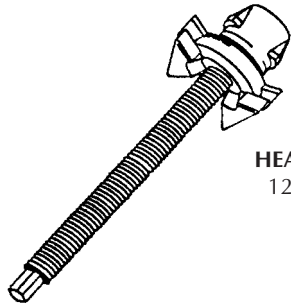

87-6256
 Replaces: E7SZ-13032C
HEADLAMP ADJUSTING ASSEMBLY
 12 - 28 x 2 1/2" Screw Zinc Finish
 Gray Plastic Nut, R.H. Lower;
 L.H. Upper
 T-Bird, Cougar '87 - '88
 Lincoln Continental
 UNIT PACKAGE 5

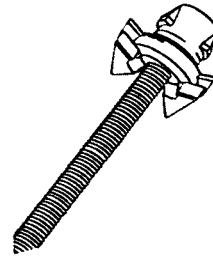

87-6258
 Replaces: E7SZ-13032D
HEADLAMP ADJUSTING ASSEMBLY
 12 - 28 x 63.5MM Screw Zinc Finish
 Gray Plastic Nut, R.H. Upper;
 L.H. Lower
 T-Bird, Cougar '87 - '88
 Lincoln Continental
 UNIT PACKAGE 5

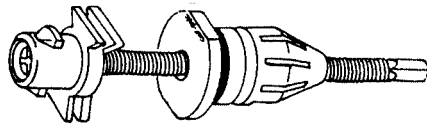

90-6772
 Replaces: E9SZ-13032A
INBOARD END
 Screw: M6 x 71.5MM O/L
 Clear Chromate Finish
 Black Nut, Gray Pivot
 T-Bird '89/
 Crown Victoria '92/
 UNIT PACKAGE 5

90-6773
 Replaces: E9SZ-13032B
CENTER BOTTOM
 Screw: M6 x 66.5MM O/L
 Bronze Chromate Finish
 Black Nut, Gray Pivot
 T-Bird '89/
 Crown Victoria '92/
 UNIT PACKAGE 5

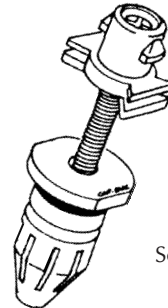

90-6774
 Replaces: E7SZ-13032C
CENTER TOP
 Screw: M6 x 47.5MM O/L
 Black Chromate Finish
 Black Nut, Gray Pivot
 T-Bird '89/
 Crown Victoria '92/
 "F" Trucks '87 - '91
 UNIT PACKAGE 5

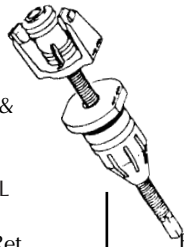

90-6775
 Replaces: E9WY-13032A &
 F2MY-13032A
HORIZONTAL
 Screw: M6 x 71.5MM O/L
 Clear Chromate Finish
 Black Nut, White Pivot w/Ret.
 Cougar '89/
 Grand Marquis '92/
 UNIT PACKAGE 5

90-6776
 Replaces: E9WY-13032B &
 F2MY-13032B
VERTICAL
 Screw: M6 x 66.5MM O/L
 Bronze Chromate Finish
 Black Nut, White Pivot w/Ret.
 Cougar '89/
 Grand Marquis '92/
 UNIT PACKAGE 5

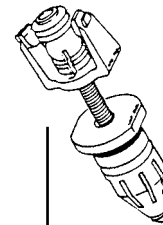

90-6777
 Replaces: E9WY-13032C
PIVOT POINT
 Screw: M6 x 47.5MM O/L
 Black Chromate Finish
 Black Nut, White Pivot w/Ret.
 Cougar '89/
 Grand Marquis '92/
 UNIT PACKAGE 5

FORD TRUCKS

AEROSTAR

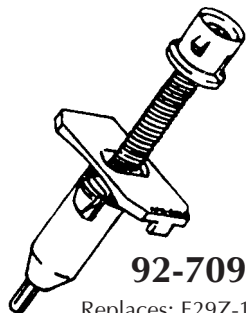

92-7090
 Replaces: F29Z-13032A
HEADLAMP ADJUSTER
 Screw: M6 x 65MM O/L
 Screw Torx Drive
 Ford Aerostar '92/'97
 UNIT PACKAGE 5

"F" SERIES (PICK-UP) & "U" SERIES (BRONCO)

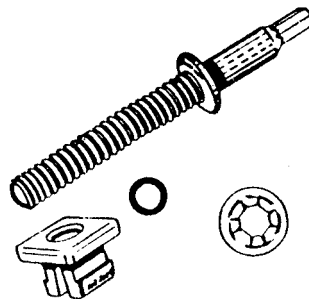

90-6784
 Replaces: E7TZ-13032B
LOWER
 Screw: M6 x 71.5MM O/L
 Black Nut "O" Ring Retainer
 Clear Chromate Finish
 Trucks '87/'91
 UNIT PACKAGE 5

EXPLORER / BRONCO II / RANGER

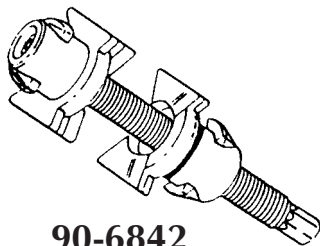
**90-6842**

Replaces: E9TZ-13032A
HEADLAMP ADJUSTER ASSY.- VERTICAL
 Screw: M6 x 60MM O/L
 Clear Chromate Finish
 Brown Nut, Gray Pivot
 Explorer, Bronco II, Ranger '89/'92
UNIT PACKAGE 5

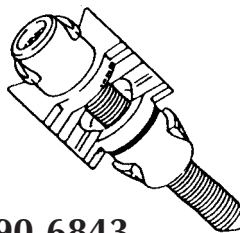
**90-6843**

Replaces: E9TZ-13032B
HEADLAMP ADJUSTER ASSY.- VERTICAL
 Screw: M6 x 42MM O/L
 Black Chromate Finish
 Brown Nut, Gray Pivot
 Explorer, Bronco II, Ranger '89/, '92
UNIT PACKAGE 5

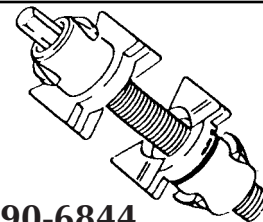
**90-6844**

Replaces: E9TZ-13032C
HEADLAMP ADJUSTER ASSY.- HORIZONTAL
 Screw: M6 x 50MM O/L
 Bronze Chromate Finish
 Brown Nut, Gray Pivot
 Explorer, Bronco II, Ranger '89/, '92
UNIT PACKAGE 5

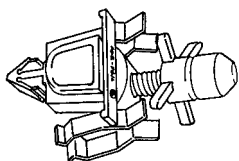
**96-7611**

Replaces: F37Z-13032-A
**Headlamp Adjusting
 Screw & Nut Assembly**
 Pivot Adjustment
 Ford Ranger '93/
UNIT PACKAGE 5

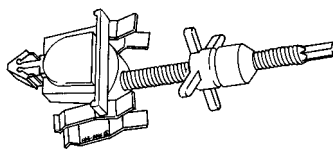
**96-7612**

Replaces: F37Z-13032-B
**Headlamp Adjusting
 Screw & Nut Assembly**
 Horizontal Adjustment
 Ford Ranger '93/
UNIT PACKAGE 5

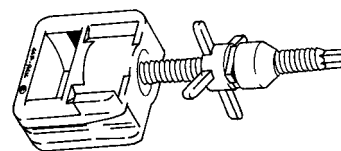
**96-7613**

Replaces F37Z-13032-C
**Headlamp Adjusting
 Screw & Nut Assembly**
 Vertical Adjustment
 Ford Ranger '93/
UNIT PACKAGE 5

CHRYSLER

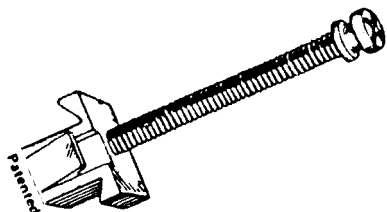
**67-3151**

**HEADLAMP ADJUSTING
 SCREW & NUT**
 Chrysler Products '67 - '70
UNIT PACKAGE 25

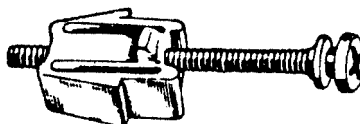
**71-3453**

Replaces: 3573797
**HEADLAMP BEAM ADJUSTING
 NUT & SCREW ASSEMBLY**
 Screw: 12 - 28 x 1 1/2"
 Chrysler Products '71/
UNIT PACKAGE 25

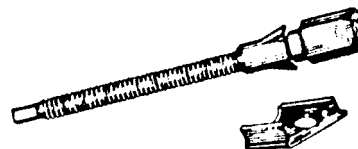
**72-3699**

**HEADLAMP ADJUSTING
 SCREW & STOP**
 Plastic
 Capri '71 - '72
 Chrysler Cricket
UNIT PACKAGE 25

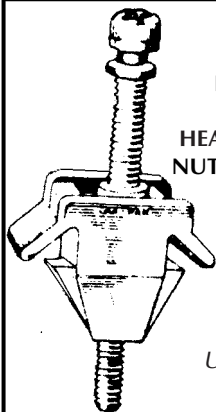
**84-5814**

Replaces: 433139,
 4334142
**HEADLAMP ADJUSTING
 NUT & SCREW ASSEMBLY**
 Slotted Torx
 Recess Screw
 Screw:
 12 - 28 x 1 1/2"
 White Nut
 Chrysler '78/
UNIT PACKAGE 25

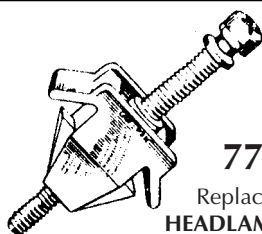
**77-4681**

Replaces: 3868985
**HEADLAMP ADJUSTING
 NUT & SCREW ASSEMBLY**
 Screw: 12 - 28 x 1 1/2"
 Chrysler Products '78/
 Diplomat & LeBaron '78/
 "K" Bodies
UNIT PACKAGE 50

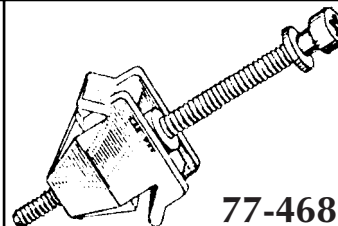
**77-4682**

Replaces: 5201269, 5201359
**HEADLAMP ADJUSTING
 NUT & SCREW ASSEMBLY**
 Screw: 12 - 28 x 2 1/8"
 Chrysler Products '78/
UNIT PACKAGE 50

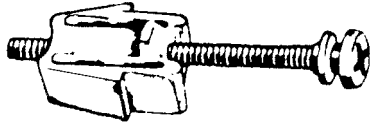

78-4809
 Replaces: 4034889
**HEADLAMP ADJUSTING
 NUT & SCREW ASSEMBLY**
 Screw: 12 - 28 x 1 1/2"
 Chrysler LeBaron &
 Dodge Diplomat '77/
UNIT PACKAGE 25

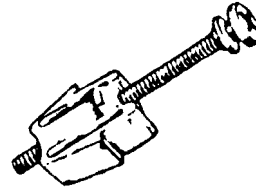

71-3526
 Replaces: 3574085
**HEADLAMP ADJUSTING
 NUT & SCREW**
 Screw: 12 - 28 x 1 1/2"
 Chrysler Products '72/
 (All Except Monaco)
UNIT PACKAGE 25

71-3527
 Replaces: 3574084
**HEADLAMP ADJUSTING
 NUT & SCREW**
 Screw: 12 - 28 x 1 1/2"
 Chrysler Products
 '72 Monaco Only
UNIT PACKAGE 25

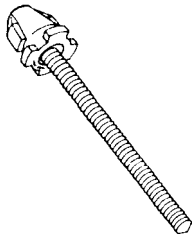

92-7091
 Replaces: 4451998, 4638431
**HEADLAMP ADJUSTER
 ASSEMBLY**
 Screw: 12 - 28 x 3 3/16" O/L Torx Drive
 Chrysler Minivans '91/
UNIT PACKAGE 5



**UNIQUE
 FASTENING PROBLEM?
 LET US HELP
 YOU SOLVE IT.
carpak@carpak.com**

AMERICAN MOTOR & TRUCK

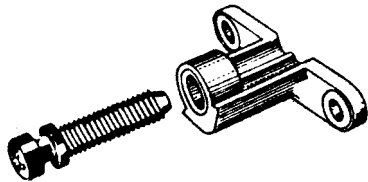

71-3481
 Not Serviced By O.E.
**HEADLAMP ADJUSTING
 NUT & SCREW**
 American Motors Cars '69 - '72
 w/Dual Headlamps
UNIT PACKAGE 25

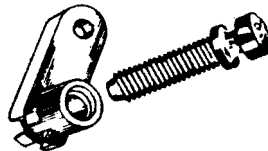

71-3482
 Not Serviced By O.E.
**HEADLAMP ADJUSTING
 NUT & SCREW**
 American Motors Cars '69 - '72
 w/Single Headlight
UNIT PACKAGE 25

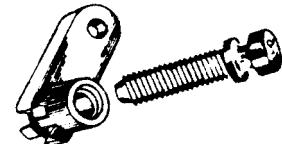

75-4140
 Not Serviced By O.E.
**HEADLAMP ADJUSTING
 NUT & SCREW**
 American Motors Cars '74 - '76
 w/Single Headlight
UNIT PACKAGE 25

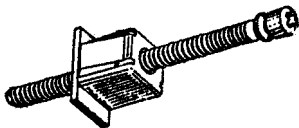

83-5747
 Replaces: 8936000-148 AMC
 176-941117 V.W.
**HEADLAMP ADJUSTING
 NUT & SCREW**
 AMC Encore, Alliance & V.W.
 Products '83/
UNIT PACKAGE 10

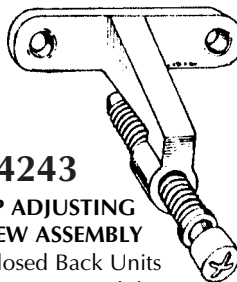

76-4243
**HEADLAMP ADJUSTING
 NUT & SCREW ASSEMBLY**
 Used on All Closed Back Units
 International Harvester, Freightliner,
 White, Mack
 Also Used on Dual Units
 Freightliner, AM General, Fixable
UNIT PACKAGE 25



HEADLAMP SCREWS



83-5683
Replaces: 9437545
SCREW-HEADLAMP ADJUSTING
12 - 28 x 1 3/8"
G.M.
UNIT PACKAGE 25

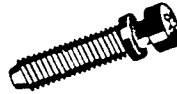

67-3111
SCREW-HEADLAMP ADJUSTING
1/4 - 28 x 1"
G.M. CARS '62 - '72
UNIT PACKAGE 50



65-1097
SCREW-HEADLAMP ADJUSTING
1/4 - 28 x 1 1/2"
G.M. '65 - '67, Ford '65 - '66
Universal for Other Cars
UNIT PACKAGE 50



68-3240
SCREW-HEADLAMP ADJUSTING
1/4 - 28 x 1 1/2"
G.M. Cars '69 - '72
UNIT PACKAGE 25



81-5410
Replaces: 9437348
SCREW-HEADLAMP ADJUSTING
12 - 28 x 1 3/4"
G.M. '76/
UNIT PACKAGE 50



75-4221
Replaces: 9432645
SCREW-HEADLAMP ADJUSTING
1/4" - 28 x 2"
G.M. Cars '75 - '76
UNIT PACKAGE 50



72-3566
Replaces: 3996200
SCREW-HEADLAMP ADJUSTING
1/4" - 28 x 2 1/8"
Camaro '71 - '72
UNIT PACKAGE 50



75-4223
Replaces: 9436928
SCREW-HEADLAMP ADJUSTING
1/4" - 28 x 2 1/4"
G.M. '76
UNIT PACKAGE 50



79-5020
Replaces: 1612276
STUD-HEADLAMP DOORS
Cadillac '77/
UNIT PACKAGE 25



67-3123
SCREW-HEADLAMP ADJUSTING
1/4" - 28 x 1 3/4", Slotted Hex Head
G.M. Cars '68
UNIT PACKAGE 50



71-3510
SCREW-HEADLAMP ADJUSTING
Ford Products w/Disappearing
Headlamps '69 - '71
UNIT PACKAGE 50



67-3121
SCREW-HEADLAMP ADJUSTING
12 - 28 x 1 1/2"
Chrysler Products '68 - '72
UNIT PACKAGE 50



86-6065
SCREW-HEADLAMP ADJUSTING
12 - 28 x 2 1/8"
Zinc Plate
Chrysler Products '78/
UNIT PACKAGE 50



83-5633
Replaces: 10023094
SCREW-HEADLAMP AIMING
Up & Down Stop for Disappearing
Headlight
G.M. '82
UNIT PACKAGE 25



87-6199
SCREW-HEADLAMP ADJUSTING
M5 x 34MM Slotted Torx
Black Phosphate Finish
UNIT PACKAGE 50

HEADLAMP PARTS



HEADLAMP NUTS, PIVOTS & SPACERS

GENERAL MOTORS

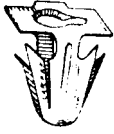

80-5153

Replaces: 25501771
NUT-HEADLAMP BEZEL RETAINING
 Olds '80/
UNIT PACKAGE 100

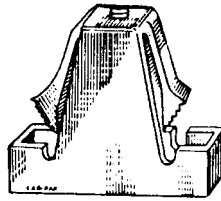

81-5327

NUT-HEADLAMP ADJUSTING
 12 - 28 Screw Size
 Olds '77/
UNIT PACKAGE 50

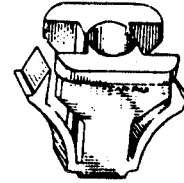

75-4129

Replaces: 343555
NUT-HEADLAMP ADJUSTING
 Chevrolet Passenger '75/
 Chevelle
UNIT PACKAGE 50

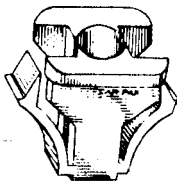

78-4808

Replaces: 365270
NUT-HEADLAMP ADJUSTING
 Green
 For Use on Fiberglass Panels
 G.M. Cars
UNIT PACKAGE 50

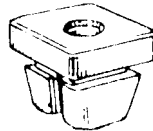

67-3122

Replaces: 3921446
NUT-HEADLAMP ADJUSTING
 G.M. Cars '68/
UNIT PACKAGE 50



NN-3001

NUT-HEADLAMP ADJUSTING
 Chevrolet, Olds, Pontiac
 Buick '62 - '72
UNIT PACKAGE 50



75-4198

Replaces: 1355003, 1370853
NUT-HEADLAMP BEZEL
 Screw: #8
 Buick '64 - '76, Olds '64 - '65
 Cadillac '65/, General Usage
UNIT PACKAGE 100



75-4199

Replaces: 3919773, 347347
NUT-HEADLAMP BEZEL
 No. 8
 Vega '74/, Chevrolet '68/
 Firebird '73/, Cadillac, "M" Vans '85/
UNIT PACKAGE 100

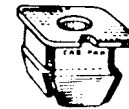

75-4200

NUT-HEADLAMP BEZEL
 G.M. Cars, Also General Purpose
UNIT PACKAGE 100

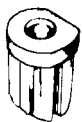

66-1173

Replaces: 5955644
NUT-HEADLAMP DOOR
 Olds (Jet Star) & Starfire '65 - '66
UNIT PACKAGE 100

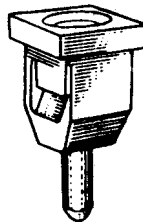

81-5458

NUT-HEADLAMP DOOR SPACER
 1/16" Head Thickness
 Olds
UNIT PACKAGE 50



80-5260

Replaces: 14013246
NUT-HEADLAMP DOORS & HEADER
 Panel
 G.M. '80/
UNIT PACKAGE 50



72-3606

Replaces: 3986978
NUT-HEADLAMP DOOR RETAINER
 Chevrolet '71/
 (8 Used Per Car)
UNIT PACKAGE 100

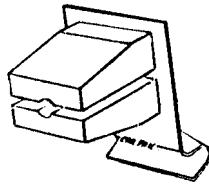

88-6374

Replaces: 16503548
GROMMET-NUT & SPRING
 Provides Tension On Headlamp
 Various Models G.M.
UNIT PACKAGE 25



95-7385

Replaces: 3783004
GROMMET NUT-HEADLAMP BEZEL
 License Plate
 Plastic
 M4.2 Screw, 7MM Square Hole
 G.M. & General Purpose
UNIT PACKAGE 50

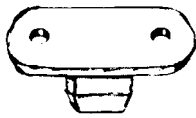

65-1138

RETAINER-HEADLAMP RIM TO GRILLE
 Chevrolet '66 - '67
 (4 Used Per Car)
UNIT PACKAGE 100

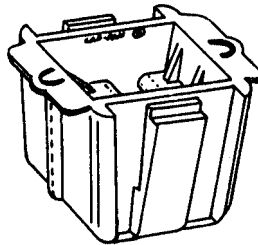

87-6289

Replaces: 90181010
RETAINER-HEADLAMP ASSY.
 Plastic
 Pontiac Lemans '88/
UNIT PACKAGE 25

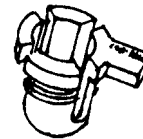

89-6620

RETAINER-PIVOT STUD
 HEADLAMP ADJUSTING SCREW
 Plastic
 Buick "H" Body '87/
UNIT PACKAGE 25

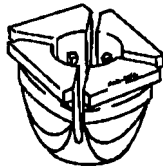

98-7788

Replaces: 16506617
SOCKET - HEADLAMP ADJUSTER PIVOT
 Plastic
 Fits 13MM Square Hole
 GM Car & Truck '87-'96
UNIT PACKAGE 25

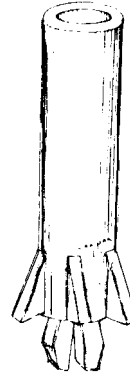

79-4997

Replaces: 10004329
SPACER-HEADLAMP
 Imported
 Pontiac '79/
UNIT PACKAGE 50

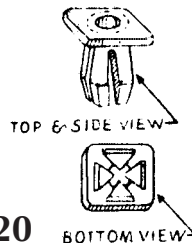

67-3120

Replaces: 379830-S
NUT-SIDE MIRROR
 Headlamp Door Attaching Nut
 Ford & Mercury '67/
 Ford, Mercury Comet '66
 General Usage
UNIT PACKAGE 100

FORD



70-3386

Replaces: 355888-S2
HEADLAMP NUT
 No. 10 Screw
 Ford Products
UNIT PACKAGE 100



66-1189

NUT-HEADLAMP BODY TO
 HEADLIGHT RIM
 Nylon, M4.2 Screw
 Ford Products '66
 General Usage
UNIT PACKAGE 100

HEADLAMP PARTS



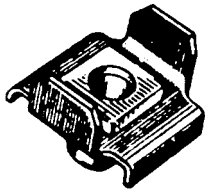

77-4700
 Replaces: D3AZ-13021A
NUT-HEADLAMP ADJUSTING
 Ford Light Trucks '73/
 General Usage
 UNIT PACKAGE 25



68-3218
NUT-HEADLAMP DOOR
 To Headlight Body Shell
 Ford Mercury '68
 UNIT PACKAGE 50

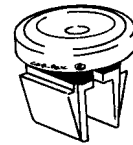

98-7849
 Replaces: F5RZ-13N129-C
GROMMET-HEADLAMP HOUSING
 TO RAD. GRILLE
 Plastic
 Screw: M5, Hole: M8 x 10MM,
 Flange: 16MM
 Ford Contour & Mystique '95/
 UNIT PACKAGE 25



92-7089
PIVOT SOCKET-HEADLAMP ADJUSTER
 Plastic
 Ford Aerostar '92/
 UNIT PACKAGE 10

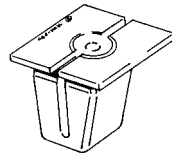

99-8155
 Replaces: YS4Z-13N129-AA
GROMMET-HEADLAMP
MOUNTING AT GRILLE OPENING
 Plastic
 Screw: M4.2, Hole: 10x13.5MM,
 Flange: 20MM sq.
 Ford Focus 2000/
 UNIT PACKAGE 15

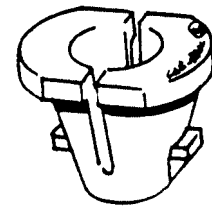

95-7464
 Replaces: FICZ-13A147A
SOCKET-HEADLAMP PIVOT
 Plastic
 Escort, Tracer '91/
 UNIT PACKAGE 25



99-8318
 Replaces: W706182-S300
RIVET - SCREW TYPE
 Headlamp Mounting
 Plastic
 Hole: M7.5, Flange: 20MM,
 Stem Lgth: 13.5MM, Hex: 10MM
 Ford Focus 2000/
 UNIT PACKAGE 25

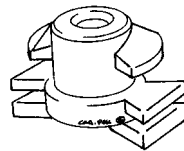

99-8202*
 Not supplied by O. E.
PIVOT-HEADLAMP ADJUSTING
 Black Plastic
 Snaps on to 12-24 adjusting screw
 Ford Tempo/Topaz '88/
 UNIT PACKAGE 25

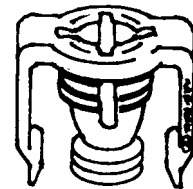

89-6651
 Not Supplied By O.E.
SOCKET ASSEMBLY-
HEADLAMP ADJUSTER
 Plastic
 Cougar '89/ & Grand Marquis '92/
 UNIT PACKAGE 10

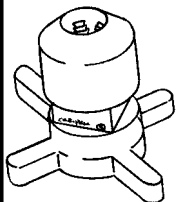

98-7871*
 Not Supplied By O.E.
NUT-HEADLAMP HOUSING
 Plastic
 Fits M6 Adjusting Screw
 Ford Mustang '96-'98, Ranger '93/
 Expedition & "F" Series Trucks '97/
 UNIT PACKAGE 25

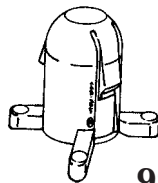

99-8142
 Not Supplied by O.E.
NUT-HEADLAMP ADJUSTING SCREW
 Plastic
 Fits M6 Adjusting Screw
 Adjusting Screw #'s F4ZZ-13032-A &
 F4ZZ-13032-B
 Ford Mustang '94-'98
 UNIT PACKAGE 15

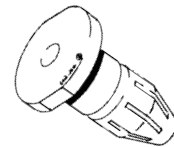

99-8200*
 Not supplied by O.E.
NUT-HEADLAMP ADJUSTING
 Black Plastic - use w/89-6651 or 99-8203
 Screw: M6
 Ford Taurus/Sable '89/, T.Bird/Cougar '89/
 Gr. Marquis/Crown Vic. '92/
 'F' Series Truck '87-'91
 UNIT PACKAGE 25

* A component for headlamp adjusters found on pages 240-243

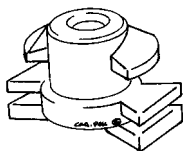
**99-8201***

Not supplied by O.E.
NUT-HEADLAMP ADJUSTING
 Brown Plastic - use w/99-8203
 Screw: M6
 Ford Escort/Lynx '88/, Explorer/Bronco II,
 Ranger '89-'92
UNIT PACKAGE 25

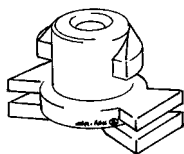
**99-8203***

Not supplied by O.E.
PIVOT-HEADLAMP ADJUSTING
 Grey Plastic - use w/99-8200 or 99-8201
 Snaps on to M6 adjusting screw
 Ford Escort/Lynx '88/, Explorer/Bronco II,
 Ranger '89-'92,
 Taurus/Sable, T.Bird/Cougar '89/,
 Marquis/Crown Vic. '92/,
 'F' Series Truck '87-'91
UNIT PACKAGE 25

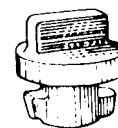
**79-4996**

Not Supplied By O.E.
HEADLAMP SPACER
 Imported
 Fiesta '78/
UNIT PACKAGE 50

CHRYSLER

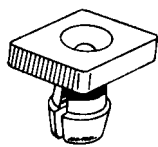

(PLASTIC)

84-5800

Replaces: 6500725
NUT-HEADLAMP BEZEL
 Black No. 10 Screw
 Chrysler "E" Class, Lebaron
 New Yorker, Dodge 400-600 '83/
UNIT PACKAGE 100

**78-4767**

Replaces: 6031138
GROMMET-HEADLIGHTS
 Chrysler Products
UNIT PACKAGE 100

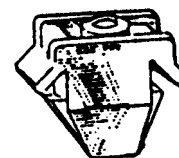
**86-6066**

NUT-HEADLAMP ADJUSTING
 Plastic (Green)
 12-28 Screw
 Chrysler '78/
UNIT PACKAGE 50

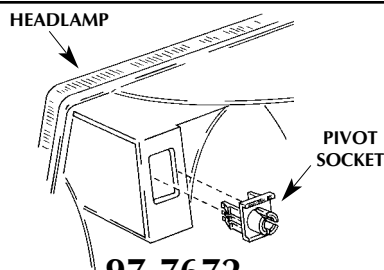
**97-7672**

PIVOT SOCKET-HEADLAMP ADJUSTER
 Plastic
 Hole: 12MM Square
 Chrysler '91/'94
UNIT PACKAGE 10

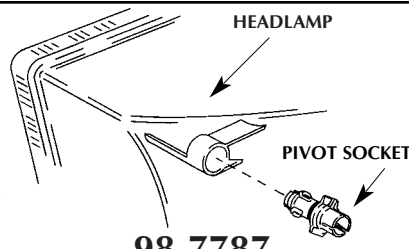
**98-7787**

Not Supplied By O.E.
PIVOT SOCKET - HEADLAMP ADJUSTER
 Plastic
 Hole: M10
 Chrysler '91 - '94
UNIT PACKAGE 10

**99-8351**

NOT SUPPLIED BY O.E.
RETAINER - HEADLAMP MOUNTING PANEL
 Plastic
 Hole: 10 X 15MM, Flange: 16 x 22MM,
 O/L: 22MM,, P.R.: 3.3MM
 Jeep Gr. Cherokee '99/
UNIT PACKAGE 25

HEADLAMP SPRINGS

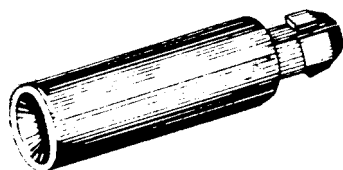
**69-3299**

Replaces: 6027014
SPACER-HEADLAMP DOOR
 Chrysler Products '68 - '69
UNIT PACKAGE 50

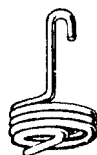
**68-3204**

Replaces: 3929918
SPRING-HEADLAMP TENSION, R.H.
 Chevy '68
UNIT PACKAGE 25

**68-3197**

Replaces: 3923948
SPRING-HEADLAMP TENSION
 Chevelle '68 - '76
UNIT PACKAGE 25

HEADLAMP PARTS

* A component for headlamp adjusters found on pages 240-243



CAR-PAK MANUFACTURING COMPANY, INC. • TROY, MI





68-3203
 Replaces: 9790354
SPRING-HEADLAMP TENSION
 Pontiac, Buick '68
UNIT PACKAGE 25



72-3623
 Replaces: 478943
SPRING-HEADLAMP ADJUSTING
 Firebird '69/, Lemans '72 - '73
 Chevelle '73
UNIT PACKAGE 25

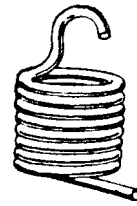

72-3624
 Replaces: 9797289
SPRING-HEADLAMP ADJUSTING
 Pontiac '69 - '70
UNIT PACKAGE 25

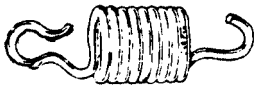

72-3608
 Replaces: 1231641
SPRING-HEADLAMP ADJUSTING
 Buick '70 - '72
UNIT PACKAGE 25



90-6741
 Replaces: D3TZ-13031-A
SPRING-HEADLAMP TENSION
 Ford Trucks '73/
UNIT PACKAGE 15

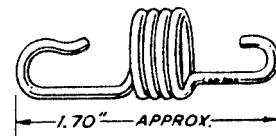

72-3649
 Replaces: 1238107
SPRING-HEADLAMP ADJUSTING
 Buick '73
UNIT PACKAGE 25

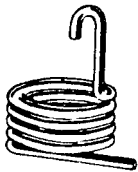

71-3484
 Replaces: 3945882
SPRING-HEADLAMP ADJUSTING
 Camaro '70 - '72
 Other G.M. Cars
UNIT PACKAGE 25



74-3989
 Replaces: 345510
SPRING-HEADLAMP ADJUSTING
 Nova, Buick, Pontiac '74/
UNIT PACKAGE 25

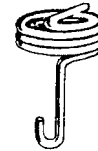

73-3898
 Replaces: 342684
SPRING-HEADLAMP TENSION
 Vega, Chevrolet & G.M.C. Truck '74
 Pontiac Astre '75 - '76
UNIT PACKAGE 25

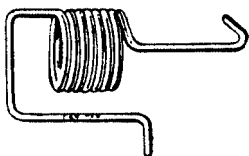

74-4099
 Replaces: 419231
SPRING-HEADLAMP ADJUSTING
 Olds '75, "C", & "E" Bodies RWD
UNIT PACKAGE 25

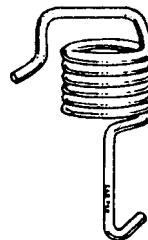

75-4218
 Replaces: 555388
SPRING-HEADLAMP ADJUSTING
 Olds '76/
 "C" Bodies '85/
UNIT PACKAGE 25



87-6290
 Replaces: 94841758
SPRING-HEADLAMP ADJUSTING
 Chevrolet Nova '85/
UNIT PACKAGE 25

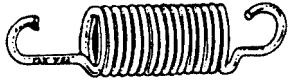

77-4626
 Replaces: 1606118
SPRING-HEADLAMP TENSION
 Cadillac, All Models
 UNIT PACKAGE 25

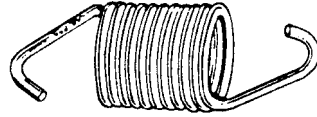

77-4701
 Replaces: 463574
SPRING-HEADLAMP TENSION
 Pontiac '78/
 UNIT PACKAGE 25

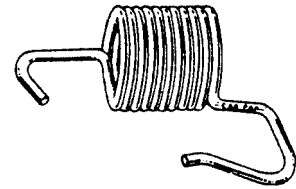

77-4702
 Replaces: 549398
SPRING-HEADLAMP TENSION
 Pontiac '78, Firebird & Camaro
 "A" & "P" Bodies
 UNIT PACKAGE 25

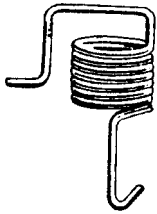

82-5533
 Replaces: 10013753
SPRING-HEADLAMP ADJUSTING
 G.M. "J" Cars '82/
 UNIT PACKAGE 25



**SHARE YOUR NEW
 ITEM SUGGESTIONS
 AND IDEAS AT:
carpak@carpak.com**

FORD

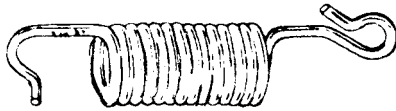

72-3663
 Replaces: D0ZZ-13031A
SPRING-HEADLAMP ADJUSTING
 Mustang '70 - '72
 UNIT PACKAGE 25

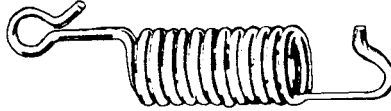

73-3927
SPRING-HEADLAMP ADJUSTING
 Mercury, Cougar '71 - '73
 UNIT PACKAGE 25

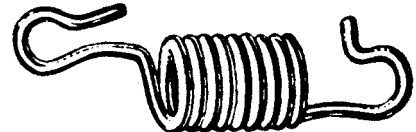

71-3504
 Replaces: D2AZ-13031A
SPRING-HEADLAMP ADJUSTING
 Ford '72
 UNIT PACKAGE 25



68-3200
 Replaces: C6AZ-13031B
SPRING-HEADLAMP TENSION
 Ford '67 - '68
 UNIT PACKAGE 25

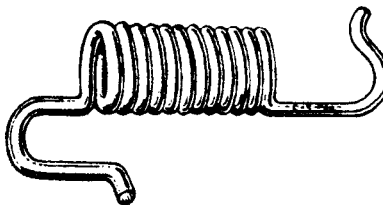

73-3820
 Replaces: D4ZZ-13031A
SPRING-HEADLAMP ADJUSTING
 Mustang, Montego
 Torino '74/
 UNIT PACKAGE 25

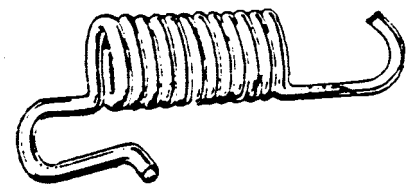

88-6390
 Replaces: D8BZ-13031A
SPRING-HEADLAMP ADJUSTING
 Ford Products '83/
 UNIT PACKAGE 15

HEADLAMP PARTS



CHRYSLER

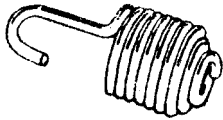

76-4239

Replaces: 6027292
SPRING-HEADLAMP TENSION
 Closed Back Assemblies
 White, Mack, Freightliner,
 International Harvester
UNIT PACKAGE 25

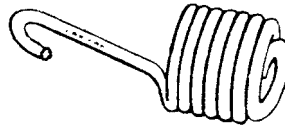

78-4772

Replaces: 3868549
SPRING-HEADLAMP TENSION
 Plymouth Fury
 Dodge Compacts '78/
UNIT PACKAGE 25

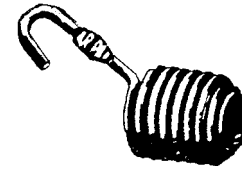

80-5222

Replaces: 5201386
SPRING-HEADLAMP ADJUSTING
 Dodge Omni, Plymouth Horizon '79/
UNIT PACKAGE 25

MISCELLANEOUS HEADLAMP PARTS

GENERAL MOTORS

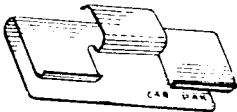

80-5224

Replaces: 1613543
CLIP-HEADLAMP DOOR RETAINING
 Cadillac '79/
UNIT PACKAGE 50



70-3369

Replaces: 9796903
RETAINER-HEADLAMP
ADJUSTING SPRING
 Pontiac Grand Prix '69 - '70
UNIT PACKAGE 50

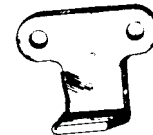

66-1194

CLIP-HEADLAMP RIM RETAINING
 Plastic
 Chevelle '67
 4 Used Per Car
UNIT PACKAGE 100

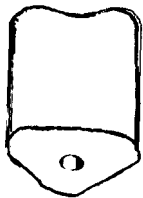

68-3177

Replaces: 3919003
RETAINER-TAIL LAMP
& BACK-UP LENS
 Nylon
 Chevrolet '68
UNIT PACKAGE 50

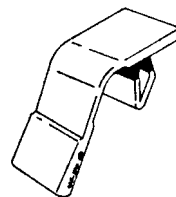

72-3577

Replaces: 1237287
BEARING PAD-RADIATOR SIDE
 Baffle or Front End
 Panel Extension
 Buick '71/
UNIT PACKAGE 100

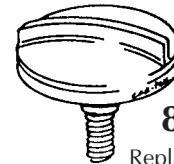
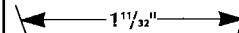

89-6640

Replaces: 14103444
SCREW
ENCAPSULATED
 (4 Per Car)
 M6-1 x 13MM Stainless Screw
 w/Black Plastic Head
 Retain Headlamp Capsule
 G.M. "L" Bodies & APV Van '87/
UNIT PACKAGE 5

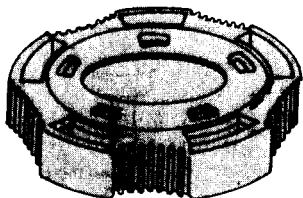

88-6373

Replaces: 16505888
RETAINER
 9004 HEADLAMP
 Composite Headlamp Assembly
 G.M. Cars
UNIT PACKAGE 5

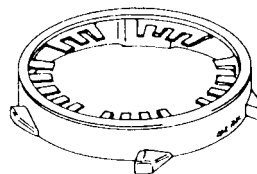

88-6379

Replaces: 16505889
GRIP RETAINER
 9004 COMPOSITE LAMP
 (4 Per Car)
 Cadillac "E", "J", "K" '86
 Olds "N" & "C" Body, Pontiac "H" Body
UNIT PACKAGE 5

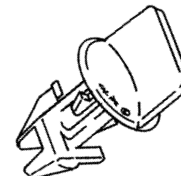

98-7872

Replaces: 25535963, N811772-S
RETAINER-SIGHT SHIELD &
H/L SHROUD COVER
 Plastic - Twist Lock
 G.M. "C", "H" & "N" Bodies '94 - '96
 Ford Full Size & Lincoln T. Car '98/
UNIT PACKAGE 15

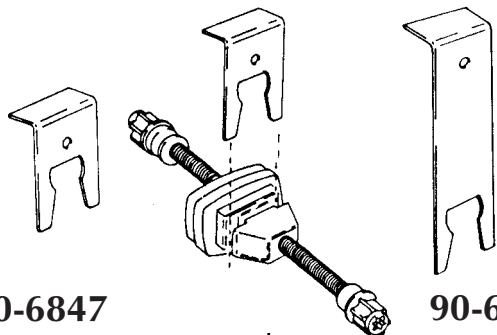

**90-6847**

Replaces: 16505619
RETAINER-HEADLAMP ADJUSTER
 INBOARD
 Pontiac Bonneville '87/
UNIT PACKAGE 15

**90-6848**

Replaces: 16508098
RETAINER-HEADLAMP ADJUSTER
 OUTBOARD
 Pontiac Bonneville '87/
UNIT PACKAGE 15

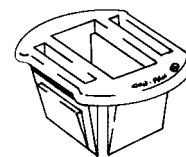
**99-8304**

Replaces: 10294517
RETAINER-HEADLAMP HOUSING PANEL
 Plastic
 Fits 10MM Slot
 G.M. APV 'U' Body Vans '97/
UNIT PACKAGE 25

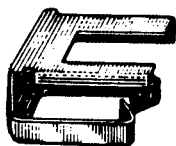
FORD**71-3472**

Replaces: D0VY-13B109C
RETAINER-HEADLAMP
 Ford Products '70 - '71
UNIT PACKAGE 25

**75-4114**

Replaces: D40Z-13B160A
BEARING-HEADLAMP ADJUSTING RING
 Maverick '74, Torino & T-Bird '74 - '75
UNIT PACKAGE 100

**72-3603**

Replaces: C9MY-13B104A
BUSHING
 Disappearing Headlamps
 Ford '69 - '70, Torino '70 - '71
 Mercury '69 - '70
UNIT PACKAGE 100

**72-3636**

Replaces: 384338-S
PIN-HEADLAMP
 Nylon
 Maverick, Comet, Cougar
 and Montego '72
UNIT PACKAGE 100

**72-3715**

Replaces: 6028689
SCREW-HEADLAMP DOOR
 Thread Size 8 - 32 x 2"
 Chrysler Products '69 - '72
UNIT PACKAGE 50

**79-5011**

Replaces: 388133-S100
CLIP
PARKING LAMP ASSEMBLY
 Ford '78/
UNIT PACKAGE 50

**88-6481**

Replaces: E5LY-13A147A
RETAINER-HEADLAMP ADJUSTER
 Escort/Lynx '86, Tempo/Topaz '86/
 Lincoln Mark III '84/'85, Merkur '85/
UNIT PACKAGE 25

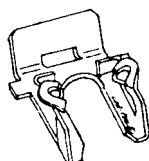
**89-6618**

Replaces: E9DZ-13N129A
RETAINER-HEADLAMP ADJUSTING BAR
 To Header Panel
 Ford Products
 w/Aerodynamic H/L Designs '86/
UNIT PACKAGE 15

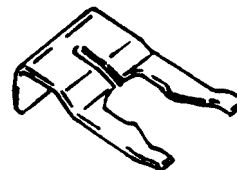
**95-7366**

Replaces: F97Z-13N129A, 5288722AA,
RETAINER-HEADLAMP ADJUSTING BAR
 & SIDE MARKER LAMPS
 To Header Panel
 Ford Ranger '93/, Mustang '94/
 Chrysler Neon 2000/
UNIT PACKAGE 15

HEADLAMP PARTS



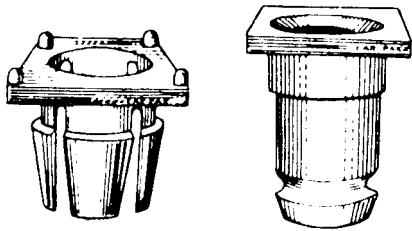

78-4789

Replaces: D6AZ-13B019A Outer
D6AZ-13B020A Inner
BEARING & BUSHING
Disappearing Headlamp Door
Ford Products '76/
UNIT PACKAGE 25 SETS

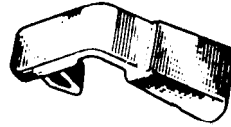

91-6888

Replaces: E2SY-13B160A
BEARING-HEADLAMP ADJUSTING RING
Plastic, 3/8" Tab
Ford '74 - '76
UNIT PACKAGE 25

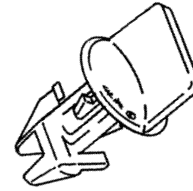

98-7872

Replaces: 25535963, N811772-S
RETAINER-SIGHT SHIELD & H/L SHROUD COVER
Plastic - Twist Lock
G.M. "C", "H" & "N" Bodies '94 - '96
Ford Full Size & Lincoln T. Car '98/
UNIT PACKAGE 15

CHRYSLER

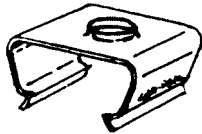

89-6719

Replaces: 6033376
RETAINER-HEADLAMP ADJUSTER
Chrysler Acclaim & Spirit '90/
UNIT PACKAGE 50

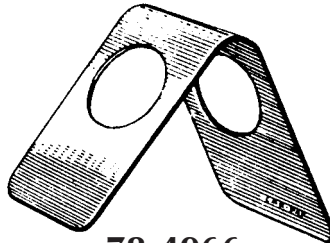

78-4966

Replaces: 6027292
CLIP-CONCEALED HEADLAMPS
Chrysler Products '77/
UNIT PACKAGE 50



92-7093

Replaces: 6502545
RETAINER-HEADLAMP SIGHT SHIELD
Plastic
Dodge Daytona '92/
UNIT PACKAGE 25



96-7525

Replaces: 55055098
RETAINER-HEADLAMP GASKET
Black Plastic
Hole: 3MM, Head: 11MM
Dodge Ram Full Size Pick Up '94
UNIT PACKAGE 25

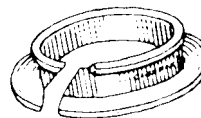

78-4784

BUSHING (SPLIT)
Disappearing Headlamp Doors
3/4" I.D.
Chrysler Products
UNIT PACKAGE 50

78-4783

BUSHING (SPLIT)
Disappearing Headlamp Doors
1/2" I.D.
Chrysler Products
UNIT PACKAGE 50

MISCELLANEOUS

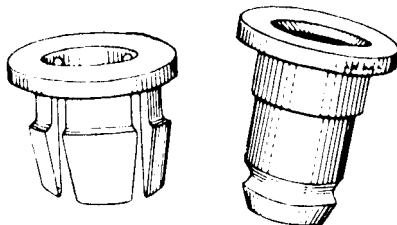

78-4788

Replaces: 4016296 Outer
4016298 Inner
BEARING & BUSHING
Disappearing Headlamp Doors
Chrysler Products '77/
UNIT PACKAGE 25 SETS

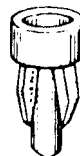

73-3824

NUT-NYLON SPACER
3/16" Head Height
Snaps Into 1/4" Hole
General Purpose
UNIT PACKAGE 100



73-3825

NUT-NYLON SPACER
1/4" Head Height
Snaps Into 1/4" Hole
General Purpose
UNIT PACKAGE 100